

# developing a flexible unitized façade system due to required re-engineering

Brombacher, Willi – Richard

independent consulting engineer VBI  
façade engineering + consultancy | interim management  
nuremberg | germany | info@wrbi.de

## Abstract:

Façade Engineering, developing of façade systems contain several disciplines such as:

- Systematic designing, based on good technical expertise of both material and building skin types
- experienced in the use of FMEA (failure mode and effect analysis), i.e. to eradicate time spent on modifications at a later stage
- Implementation of Value engineering, i.e. to get a clear picture of the true costs and to evaluate potential cost savings
- Consideration of the sustainability and safety aspect, i.e. to get a clear picture of the costs for maintenance and repair, to avoid any danger to life

Re-engineering at a running project faces the leader, in addition to the before mentioned aspects, with an increased complexity of the project process itself and the interpersonal aspect can become a more important part than at a standard project course.

With the focus on the technical aspects we are summarizing that a precise and in depth-analysis of key points is the basis for the development of innovative building skins and a successful re-engineering of the same.

The result of this methodical analysis must be used for further assessments and in the present case for the assessment of the initial façade design, the study of improvement and for the study of an alternative facade design.

In general engineering is following one of the principles of responsible project planning which is: "from gross to subtle", even if the content related meaning of gross and subtle can be different depending to the task.

In the present case we define the gross as the evaluation of key points – the main KO criteria, the subtle as the criteria's for the re-engineering itself – the requirement specification.

## Introduction

The façade we are speaking about is the "Shanghai Campus", which is a real estate investment of a leading European pharmaceutical Group. The Campus contains an ensemble of seven buildings designed by different international architects.

The speaker was, in the course of his job as technical interim director facade engineering asked to take over the lead and responsibility for the needed re-engineering (concept and scheme design level) of the façades of all buildings.

The re-engineering was required by the client who wants the highest standard in building skins.

# 1. shanghai campus – group of buildings

As initially mentioned the Shanghai campus comprises of a set of 7 buildings, named C4, C5, C6, C10, C11-1, C 11-2 and C 12.

The buildings, except C12, are designed to have a main building and subsequent courtyard.



Figure 1: architectural model and picture of the group of buildings

The architects designed a lively building complex by using many different building envelope materials such as steel, stainless steel, wood, glued + compressed bamboo stripes, rebirthed bricks, CFRC, lime stone, bronze sheets + profiles, terracotta tiles and, of course, glass.

Below pictures are of the façade mock-ups



Figure 2: C11-1 building



Figure 3: C11-2 building

The C11- 1 building envelope done by bronze sheets + profiles covering stick facade, concrete columns cladded with lime stone units.

The C11- 2 building envelope done by bronze sheets + profiles covering stick facade, CFRC concrete columns + GFRC cladded balcony

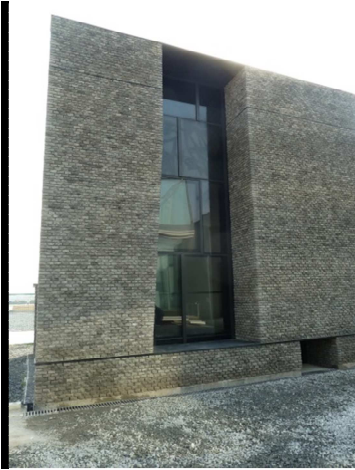

Figure 4: C4 building



Figure 5: C5 building

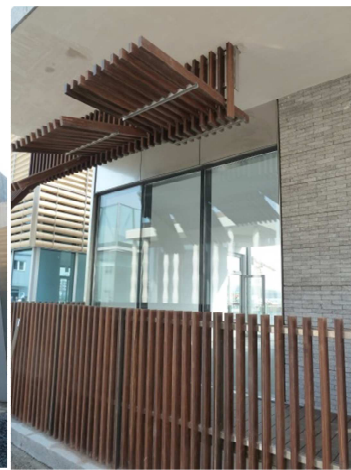

Figure 6: C6 building

The C4 building cladded by aluminium stick and unitized façade,  
building structure cladded with rebirthed bricks

The C5 building cladded with stainless steel stick façade and terracotta tiles

The C6 building cladded with aluminium stick façade, concrete cladded with brick façade, balustrades done by compressed and glued bamboo stripes

And finally a picture of the mock-up of the façade C 10,  
which is the façade which will be discussed following.

Figure 7: C10 building – still built as stick façade / steel add-on top



## 2. C10 facade



Figure 8: C10 building

The building C10 has been designed by Zhang Ke | ZAO | standardarchitecture | China and consists of a 6 Level high main building and a large courtyard.

The ambitious facade of the main building is designed with significant, impressive glass units with a height of about 5.0m at the upper level, 6.75m at ground floor level, a width of 1.2 – 2.4m and slim horizontal cantilever running around the building.

Since the client urged us to increase the level of prefabrication for all facades the speaker myself was asked personally to go for unitized façade at C10 as well and to develop a façade system suitable for all façade types of C10.

The challenging aspect was the fact of having more than 500 different horizontal angles at the zigzag layout of the façade (view from below different from layout) and a corresponding number of different positive/negative inclinations in X/Z direction of the mullions

## 3. initially and second design

The initial design envisaged a steel ad-on top stick façade, the inner secondary steel covered with aluminium sheets, the outer vertical glass joints sealed.

In other words the initially design was based on nearly 100% on site assembly

The second design planned to improve the first design concept by increasing the level rate of pre-fabrication.

This second design concept envisaged keeping the secondary steel but replacing the steel add-on construction by prefabricated thin aluminium extrusion frames with the glass structural bonded at them.

To do so the steel mullion should be carried out laterally with small steel straps every 250mm.

The vertical extrusion itself should have millings every 250mm to fit with the before mentioned straps.

Finally the plan was to cover the steel mullion and façade frame inside with three parted aluminium sheets, respectively three aluminium extrusions.

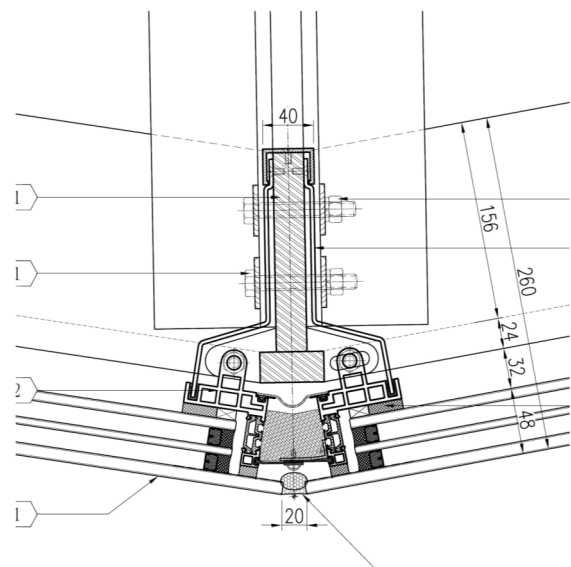

Figure 9: second design concept

The initial design was rejected due to the level rate of on-site assembly and the second design was rejected due to the needed tight tolerances of the steel mullion refer to deformation, accuracy of installation and accuracy of fabrication of the lateral steel straps. The still high level rate of on-site assembly of further buildings parts to complete the façade was a second criteria for exclusion.

#### 4. brainstorming as part of design process

The title of this chapter is inter alia named brainstorming process to underline that during the re-engineering we did not exclude façade systems from the beginning saying “unitized façade” is the first choice or “semi SG Façade” is the first choice.

The procedure of brainstorming is to collect ideas open minded, without evaluating anyone of them. The evaluation required afterward in terms of considering FMEA (Failure mode and effect analysis), value engineering and sustainability etc. is a part of systematic designing.

Both together has been characterizing the design process of the C10 Façade.

The first questions – in terms of the magic triangle – are:

- do we have time to develop a new façade system?
- do we have the budget to go for a perhaps more expensive façade system?
- what level of quality has bend specified?

some charateristic items of the design process

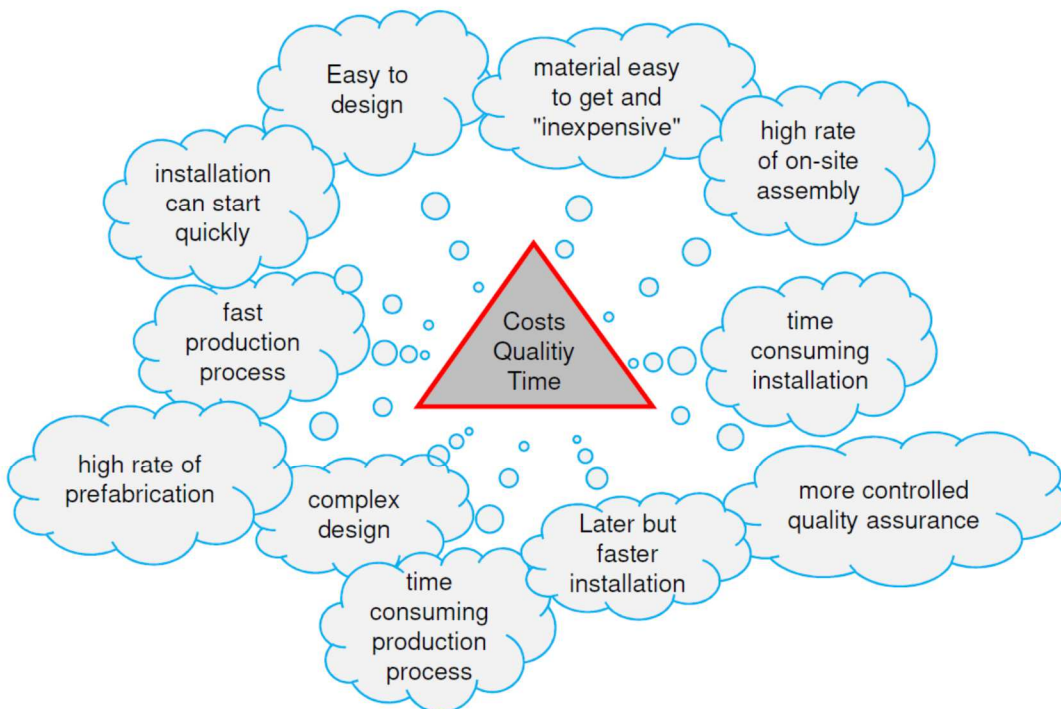

table 1: characteristic thoughts pro / cons of stick façade / unitized façade

The answers of these and further questions (as shown at table 1) are pointing in the direction, showing the basic type of the façade which must be developed.

For the C10 façade we stated very clearly:

- It is enough time to design and develop a new unitized façade system, for the consultant as well as for the façade contractor
- all the local façade contractors have the required utilities at the factory or enough time to set-up a new factory / to upgrade the fabrication if needed
- we have to keep highest quality, as demanded by the client, since the budget will cover the announced quality requirement

At this point we are encouraged to analyze the existing façade design to get a clear picture if an improvement will lead to success or if re-engineering, the developing of a new façade system will be a must.

### 5. systematic designing as part of design process – the “gross”

At this stage we created a rough chart (table 2) with the key points of assessment – these key points are the KO criteria and can be identified before having a look at specific design details.

Depending on the backdrop and the point of view of the assessor the evaluation of the below mentioned items vary and red lights must not be a supreme value for an exclusion.

For the present case green lights for all items were essential – unfortunately the evaluation for the second design as shown below and the need of a fundamental re-engineering became evident.

Even an improvement of the second design could not lead to the quality level the client has asked for and – in the end – has paid for.

gross points - ko criteria

item	Description	Status		
1	meets the architectural design intent			
2	fulfils the performance characteristic			
3	design is well thought out			
3.1	is to fabricate as drawn			
3.2	is to install as drawn, without not planned modifications on site			
4	value engineering / due diligence is done			
5	FMEA is done			
6	meets the quality as specified by client			

table 2: main KO criteria chart

### 6. systematic designing as part of design process – the “subtle”

In the previous chapter we figured out the essential requirements of the façade system. The next step was to substantiate the additional needs for further development and the design re-engineering (table 3).

Having a look at “item 1 – architectural intent”: we were asked to design the mullions as low-key elements, with a consistent view from inside – with the result to go for a trapezoidal geometry of the mullions and the need to move the inflexion point, the pivot point to outside.

Item 2 “fulfill the performance characteristic” is a key point and therefore the design must be thought out to pass the performance test without complications – even it is a matter of course we were asked to be focused onto a proper outer water repellent line.

The fulfillments of item 3 “Design is well thought out” till item 3.2 “to install as drawn” is mandatory and was given since the façade design has been transferred into a full BIM Model.

The items 4 “value engineering” and item 5 “ FMEA” has pointed into designing an adapter frame instead of bonding the triple glass at the aluminium frame directly and into the direction of using heat soak tested tempered glass instead of laminated glass as the outer pane.

Following the above conclusions the mullion consequently has 3 functional main parts:

- the trapezoidal designed mullion to follow the architectural design intend, dimensions and inner geometry optimized to bear the arising loads
- the pivot point element which allows to follow any angles
- the adapter frame to get the glass replaced without further problems in a short time

design criteria re-engineering

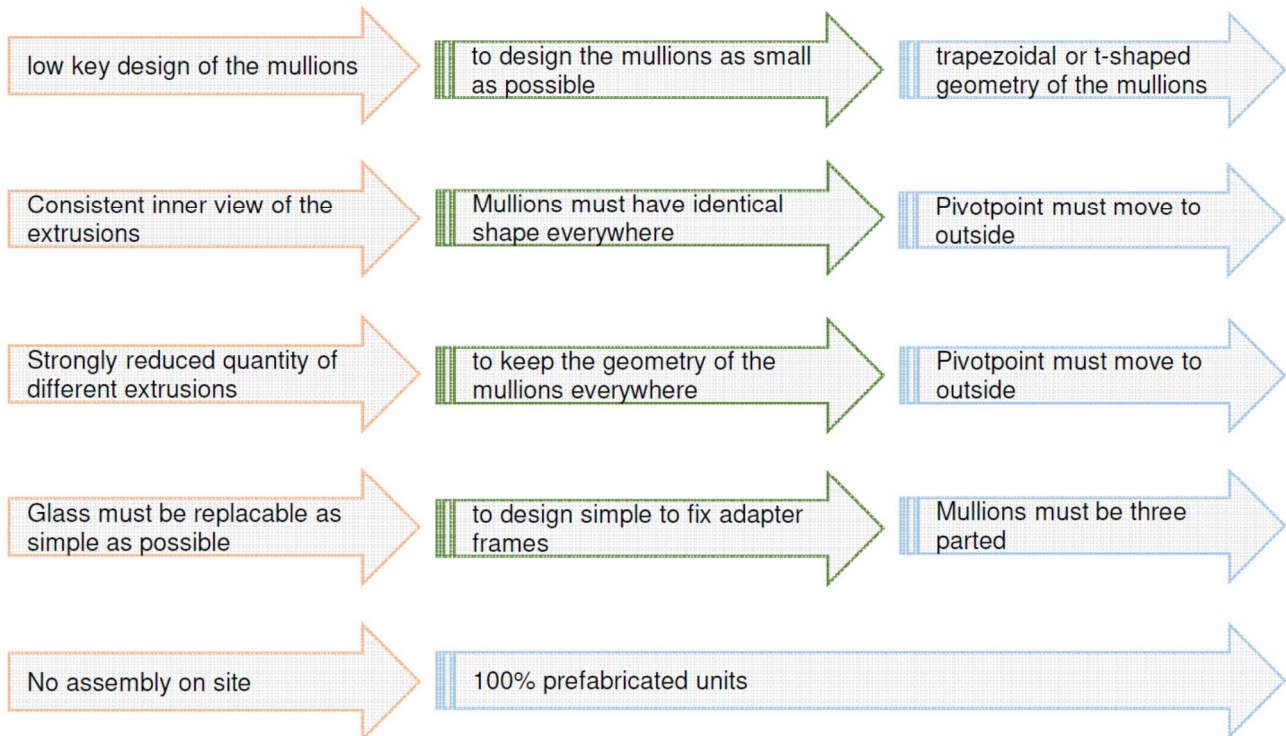

table 3: design requirements chart

## 7. final redesign façade system

All the before listed questions, answers and decisions let us come to a design as shown at figure 10 which shows the scheme design of the new façade system.

At figure 11 the pursued design by the façade contractor Yuanda is shown, with incorporated company specific implementations.

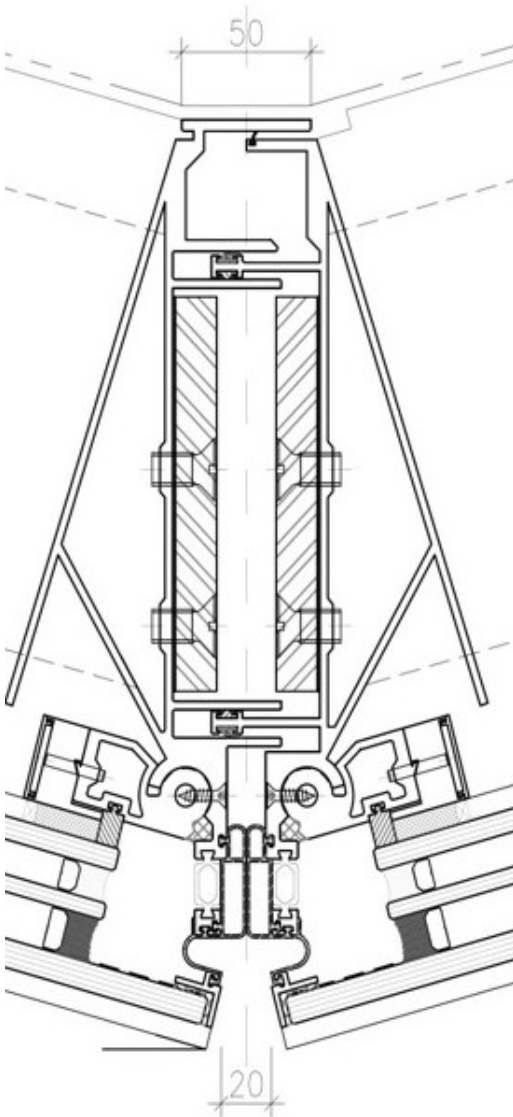

figure 10:  
detail of the developed façade mullion

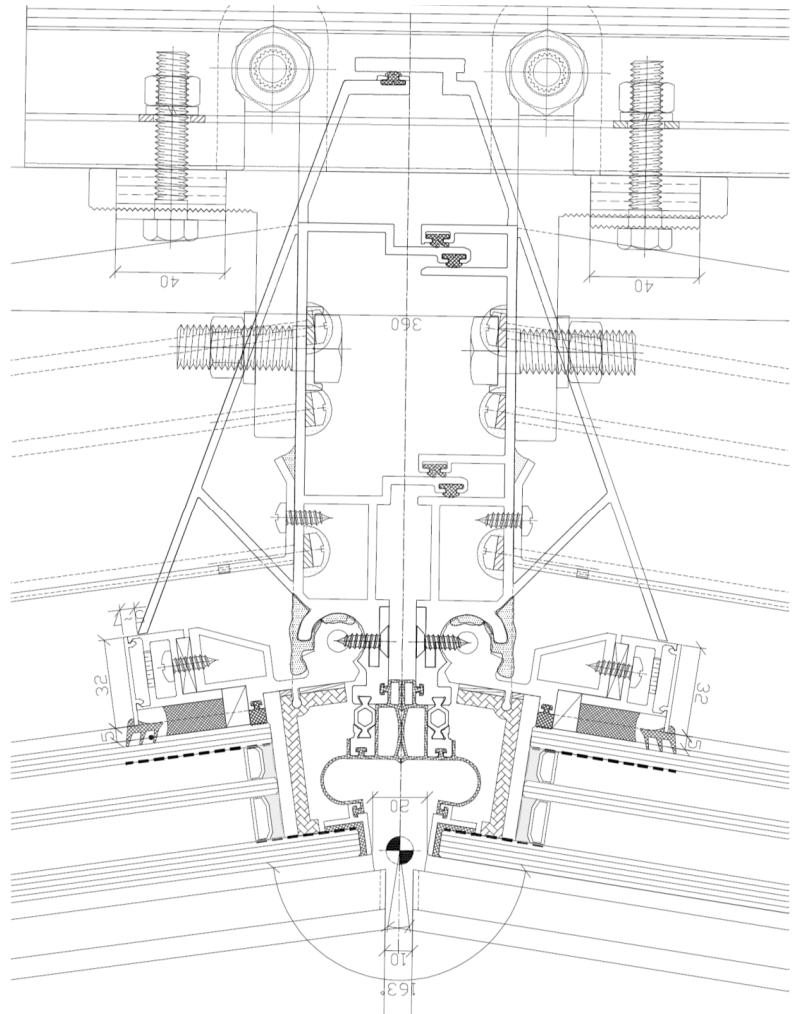

Figure 11:  
later design of Yuanda





Figure 12 + 13: Test of the performance mock up done by the facade contractor yuanda

After passing the performance Test and fulfilling the Quality criteria's the follow -up check has shown that the re-engineering was done in a right way.

item	Description	Status		
1	meets the architectural design intent			
2	fulfils the performance characteristic			
3	design is well thought out			
3.1	is to fabricate as drawn			
3.2	is to install as drawn, without not planned modifications on site			
4	value engineering / due diligence is done			
5	FMEA is done			
6	meets the quality as specified by client			

table 4: follow up chart of KO criteria's

## 8. Summarizing and retrospective:

Systematic design is a need for engineering and absolutely essential for re-engineering. Even if the content of the “KO criteria” and “design criteria” charts will be different, the most important point might be to follow a given sequence like:

1. Brainstorming
2. Collect and evaluate KO criteria
3. Collect and evaluate design criteria
4. Start the design process itself

The naming of the single steps might vary but it will follow the principle “from gross to subtle”



*Figure 14: Impression of the building*

©Novartis